



**INTERCONNECTION
FACILITIES STUDY
REPORT**

GEN-2017-181

Published Jan 2023

By SPP Generator Interconnections Dept.

REVISION HISTORY

DATE OR VERSION NUMBER	AUTHOR	CHANGE DESCRIPTION
January 20, 2023	SPP	Initial draft report issued.
February 14, 2023	SPP	Final report issued.
June 28, 2024	SPP	Upgrades revised to reflect latest study.

CONTENTS

Revision History	i
Summary	1
Introduction	1
Phase(s) of Interconnection Service	1
Compensation for Amounts Advanced for Network Upgrade(s).....	1
Interconnection Customer Interconnection Facilities	2
Transmission Owner Interconnection Facilities and Non-Shared Network Upgrade(s)	3
Shared Network Upgrade(s)	4
Contingent Network Upgrade(s).....	5
Affected System Upgrade(s)	6
Conclusion.....	7
Appendices	8
A: Transmission Owner’s Interconnection Facilities Study Report and Network Upgrades Report(s).....	9

SUMMARY

INTRODUCTION

This Interconnection Facilities Study (IFS) for Interconnection Request GEN-2017-181 is for a 300 MW generating facility located in Lancaster County, NE. The Interconnection Request was studied in the DISIS-2017-002 Impact Study for ERIS. The Interconnection Customer's requested in-service date is December 8, 2024.

The interconnecting Transmission Owner, Nebraska Public Power District (NPPD), performed a detailed IFS at the request of SPP. The full report is included in Appendix A. SPP has determined that full Interconnection Service will be available after the assigned Transmission Owner Interconnection Facilities (TOIF), Non-Shared Network Upgrades, Shared Network Upgrades, Contingent Network Upgrades, and Affected System Upgrades that are required for full interconnection service are completed.

The primary objective of the IFS is to identify necessary Transmission Owner Interconnection Facilities, Network Upgrades, other direct assigned upgrades, cost estimates, and associated upgrade lead times needed to grant the requested Interconnection Service.

PHASE(S) OF INTERCONNECTION SERVICE

It is not expected that Interconnection Service will occur in phases. However, full Interconnection Service will not be available until all Interconnection Facilities and Network Upgrade(s) can be placed in service.

COMPENSATION FOR AMOUNTS ADVANCED FOR NETWORK UPGRADE(S)

FERC Order ER20-1687-000 eliminated the use of Attachment Z2 revenue crediting as an option for compensation. The Incremental Long Term Congestion Right (ILTCR) process will be the sole process to compensate upgrade sponsors as of July 1st, 2020.

INTERCONNECTION CUSTOMER INTERCONNECTION FACILITIES

The Generating Facility is proposed to consist of one hundred fifty (150) 2.0 MW - GE 2.0 WTG Wind Turbine Generation Systems for a total generating nameplate capacity of 300 MW.

The Interconnection Customer's Interconnection Facilities to be designed, procured, constructed, installed, maintained, and owned by the Interconnection Customer at its sole expense include:

- 34.5 kV underground cable collection circuits;
- 34.5 kV to 345 kV transformation substation with associated 34.5 kV and 345 kV switchgear;
- One 345/34.5 kV 201/268/335 MVA (ONAN/ONAF/ONAF) step-up transformer to be owned and maintained by the Interconnection Customer at the Interconnection Customer's substation;
- 35 mile overhead kV line to connect the Interconnection Customer's substation to the Point of Interconnection ("POI") at the 345 kV bus at existing Transmission Owner substation ("Tobias 345kV") that is owned and maintained by Transmission Owner;
- All transmission facilities required to connect the Interconnection Customer's substation to the POI;
- Equipment at the Interconnection Customer's substation necessary to maintain a composite power delivery at continuous rated power output at the high-side of the generator substation at a power factor within the range of 95% lagging and 95% leading in accordance with Federal Energy Regulatory Commission (FERC) Order 827. The Interconnection Customer may use inverter manufacturing options for providing reactive power under no/reduced generation conditions. The Interconnection Customer will be required to provide documentation and design specifications demonstrating how the requirements are met; and,
- All necessary relay, protection, control and communication systems required to protect Interconnection Customer's Interconnection Facilities and Generating Facilities and coordinate with Transmission Owner's relay, protection, control and communication systems.

TRANSMISSION OWNER INTERCONNECTION FACILITIES AND NON-SHARED NETWORK UPGRADE(S)

To facilitate interconnection, the interconnecting Transmission Owner will perform work as shown below necessary for the acceptance of the Interconnection Customer’s Interconnection Facilities.

Table 1 and **Table 2** lists the Interconnection Customer’s estimated cost responsibility for Transmission Owner Interconnection Facilities (TOIF) and Non-Shared Network Upgrade(s) and provides an estimated lead time for completion of construction. The estimated lead time begins when the Generator Interconnection Agreement has been fully executed.

Table 1: Transmission Owner Interconnection Facilities (TOIF)

Transmission Owner Interconnection Facilities (TOIF)	Total Cost Estimate (\$)	Allocated Percent (%)	Allocated Cost Estimate (\$)	Estimated Lead Time
<u>Transmission Owner’s Tobias 345kV GEN-2017-181 Interconnection (TOIF) (NPPD) (143449):</u> Interconnect the following Interconnection Customer facility, GEN-2017-181 (300 MW/Wind), into the Point of Interconnection (POI) at Tobias 345kV	\$0	100%	\$0	N/A
Total	\$0		\$0	

Table 2: Non-Shared Network Upgrade(s)

Non-Shared Network Upgrades Description	ILTCR	Total Cost Estimate (\$)	Allocated Percent (%)	Allocated Cost Estimate (\$)	Estimated Lead Time
<u>N/A</u>	N/A	N/A	N/A	N/A	N/A
Total		N/A		N/A	

SHARED NETWORK UPGRADE(S)

The Interconnection Customer’s share of costs for Shared Network Upgrades is estimated in **Table 3** below.

Table 3: Interconnection Customer Shared Network Upgrade(s)

Shared Network Upgrades Description	ILTCR	Total Cost Estimate (\$)	Allocated Percent (%)	Allocated Cost Estimate (\$)	Estimated Lead Time
<u>Transmission Owner’s Tobias 345kV Interconnection Expansion (DISIS-2017-002)(143448)</u> Expand the Tobias 345kV substation to accommodate the interconnection of GEN-2017-181 and GEN-2017-182	Ineligible	\$7,200,000	70.09%	\$5,046,480	36 Months
<u>Transmission Owner’s - Mark Moore 345-115 kV Transformer Replacement (156456)</u> : Replace Mark Moore 345/115 kV Transformer to achieve a minimum rating of 336 MVA	Eligible	\$8,300,000	47.03%	\$3,903,142	60 Months
Total		\$15,500,000		\$8,949,622	

All studies have been conducted assuming that higher-queued Interconnection Request(s) and the associated Network Upgrade(s) will be placed into service. If higher-queued Interconnection Request(s) withdraw from the queue, suspend or terminate service, the Interconnection Customer’s share of costs may be revised. Restudies, conducted at the customer’s expense, will determine the Interconnection Customer’s revised allocation of Shared Network Upgrades.

CONTINGENT NETWORK UPGRADE(S)

Certain Contingent Network Upgrades are **currently not the cost responsibility** of the Interconnection Customer but will be required for full Interconnection Service.

Table 4: Interconnection Customer Contingent Network Upgrade(s)

Contingent Network Upgrade(s) Description	Current Cost Assignment	Estimated In-Service Date
<u>Multi - Gentleman - Cherry Co. - Holt Co. 345 kV (50442, 50445, 50444)</u> : Build approximately 110 miles of new 345kV line from Gentleman to Cherry County and 117 miles from Cherry County to Holt County (NTC - 200220)	\$0	12/31/2026

Depending upon the status of higher- or equally-queued customers, the Interconnection Request’s in-service date is at risk of being delayed or Interconnection Service is at risk of being reduced until the in-service date of these Contingent Network Upgrades.

AFFECTED SYSTEM UPGRADE(S)

To facilitate interconnection, the Affected System Transmission Owner will be required to perform the facilities study work as shown below necessary for the acceptance of the Interconnection Customer’s Interconnection Facilities. **Table 5** displays the current impact study costs provided by either MISO or AECI as part of the Affected System Impact review. The Affected System facilities study could provide revised costs and will provide each Interconnection Customer’s allocation responsibilities for the upgrades.

Table 5: Interconnection Customer Affected System Upgrade(s)

Affected System Upgrades Description	Total Cost Estimate (\$)	Allocated Percent (%)	Allocated Cost Estimate (\$)
<u>Rebuild 5.58-mile-long Conway to Phillipsburg 69 kV line with 336.4 ACSR rated at 100C</u>	\$5,040,000	5.89%	\$296,738
Total	\$5,040,000		\$296,738

CONCLUSION

After all Interconnection Facilities and Network Upgrades have been placed into service, Interconnection Service for 300 MW can be granted. Full Interconnection Service will be delayed until the TOIF, Non-Shared NU, Shared NU, Contingent NU, Affected System Upgrades that are required for full interconnection service are completed. The Interconnection Customer’s estimated cost responsibility for full interconnection service is summarized in the table below.

Table 6: Cost Summary

Description	Allocated Cost Estimate
Transmission Owner Interconnection Facilities Upgrade(s)	\$0
Non-Shared Network Upgrade(s)	\$0
Shared Network Upgrade(s)	\$8,949,622
Affected System Upgrade(s)	\$296,738
Total	\$16,421,556.16

Use the following link for Quarterly Updates on upgrades from this report: <https://spp.org/spp-documents-filings/?id=18641>

A draft Generator Interconnection Agreement will be provided to the Interconnection Customer consistent with the final results of this IFS report. The Transmission Owner and Interconnection Customer will have 60 days to negotiate the terms of the GIA consistent with the SPP Open Access Transmission Tariff (OATT).

APPENDICES

**A: TRANSMISSION OWNER'S INTERCONNECTION FACILITIES STUDY
REPORT AND NETWORK UPGRADES REPORT(S)**

See next page for the Transmission Owner's Interconnection Facilities Study Report and Network Upgrades Report(s).

**NPPD DISIS-2017-002
FACILITY STUDY**

JANUARY 2023

**PREPARED FOR:
SOUTHWEST POWER POOL**

**PREPARED BY:
NEBRASKA PUBLIC POWER DISTRICT
ENERGY DELIVERY
TRANSMISSION ASSET PLANNING
ENGINEERING & ASSET MANAGEMENT**



Nebraska Public Power District

"Always there when you need us"

The *NPPD DISIS-2017-002 Facility Study* was performed to document the interconnection facilities and network upgrades identified by SPP in Phase 3 of the SPP DISIS-2017-002 Study. The NPPD Facility Study includes detailed cost estimates and estimated project schedules for the upgrades identified in the SPP studies.

Interconnection Facility Upgrades

NPPD's Engineering, Asset Management, and Project Management groups have reviewed the interconnection facility upgrades that are required for SPP DISIS-2017-002 Generation Interconnection projects. Detailed cost estimates have been prepared for the facility upgrades that were identified in the system impact study for the requests. The prepared cost estimates are study level estimates (+20%/-20%) and assume implementation of standard NPPD construction and procurement practices. The cost estimates for the interconnection facilities are below:

- Holt County 345 kV Expansion
 - GEN-2017-144
 - 200 MW Wind
 - Add 345 kV bay
 - 36 Month Lead Time

\$ 2,500,000

- Tobias 345 kV Expansion
 - GEN-2017-181 and GEN-2017-182
 - 428 MW Wind
 - Expand substation to east and add 345 kV bay
 - assume shared gen tie line
 - 36 Month Lead Time

\$ 7,200,000

- Turtle Creek 345 kV Shared Gen-Tie Line
 - GEN-2017-201
 - 250 MW Wind
 - Shared gen tie line with GEN-2015-007
 - 12 Month Lead Time

\$50,000

- McCool 345 kV Expansion
 - GEN-2017-210
 - 310 MW Solar
 - Expand substation to west and add 345 kV bay
 - 36 Month Lead Time

\$ 9,900,000

- Greeley 115 kV Substation (Spalding – North Loup 115kV Line)
 - GEN-2017-234
 - 115 MW Wind
 - Build new 115 kV substation on Spalding – North Loup 115 kV line near Greeley, NE. Project scope includes substation, line, and telecom work to build substation at this location.
 - 36 Month Lead Time

\$12,500,000

Network Upgrades

NPPD’s Engineering, Asset Management, and Project Management groups have reviewed the network upgrades that are required for SPP DISIS-2017-002 Generation Interconnection projects. Detailed cost estimates have been prepared for the facility upgrades that were identified in the system impact study for the requests. The prepared cost estimates are study level estimates (+20%/-20%) and assume implementation of standard NPPD construction and procurement practices. The cost estimates for the network upgrades are below:

- Mark Moore 345-115 kV Transformer Replacement
 - Replace existing transformer with 417 MVA unit
 - 60 Month Lead Time

\$ 8,300,000

The results of DISIS-2017-002 documented that several Generation Interconnection requests are contingent on the completion of the following previously allocated required network upgrades:

- Gentleman – Thedford - Holt County (R-Project) and Thedford 345/115 kV Transformer project

Project schedule details will be further discussed in the development of the generator interconnection agreements (GIA) and the milestones associated with the generation interconnection projects.

If the generation interconnection projects proceed to the generation interconnection agreement, then an operating study may need to be performed to fully assess and evaluate the operation of the generation facility and network upgrades in accordance with NERC Standards. The operating study requirement will be included in the generation interconnection agreement with NPPD. If any generation interconnection projects are identified to have significant impact on the GGS Stability Interface (Flowgate #6006) and LRS/DC stability limitations in western NE, then the operating study will need to take these issues into account.

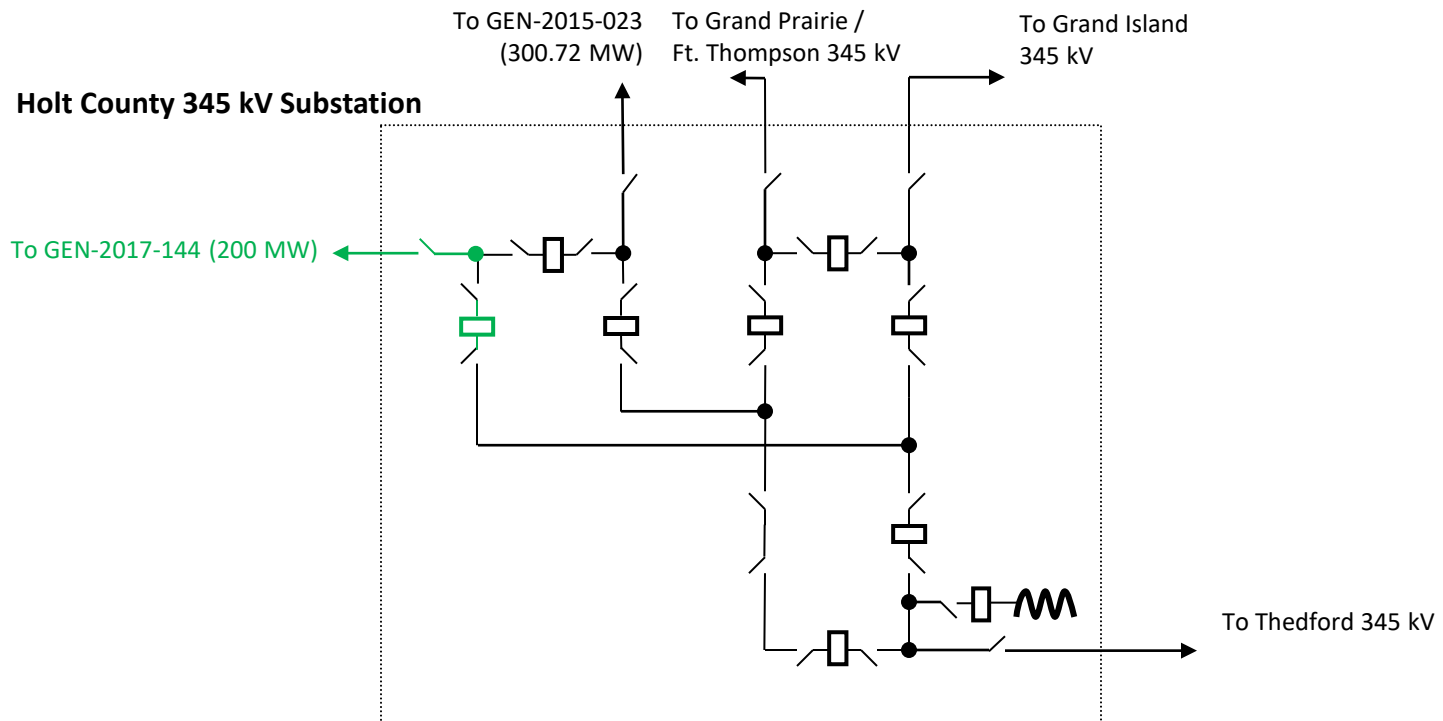

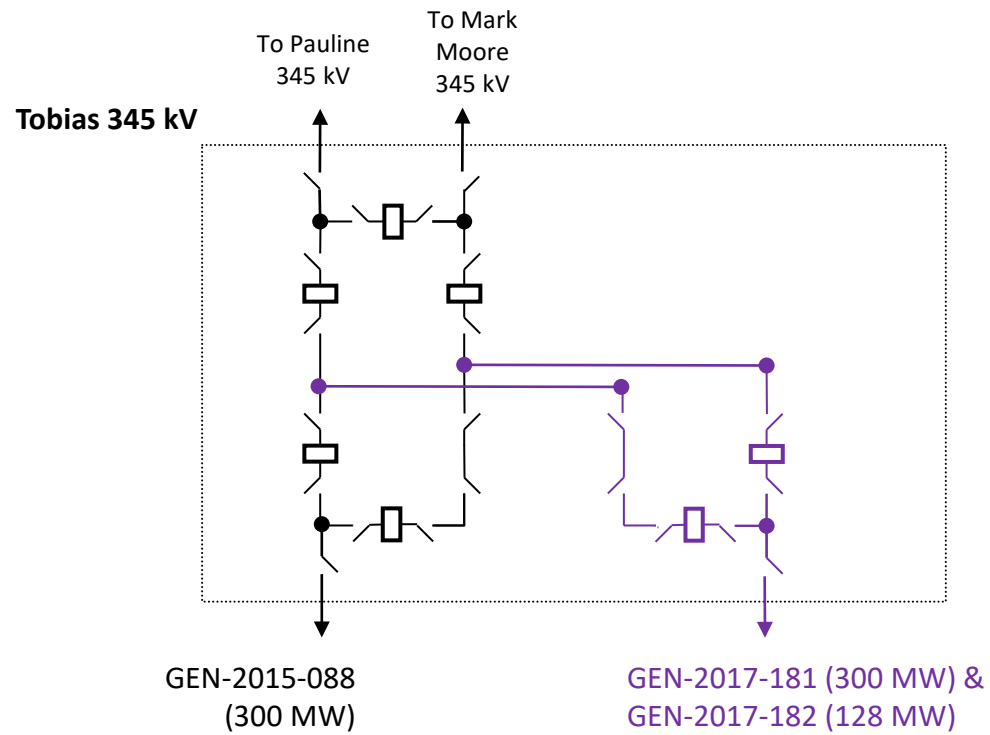

- DISIS-2015-002 Interconnection Facilities for GEN-2015-088
- DISIS-2017-002 Interconnection Facilities for GEN-2017-181 & GEN-2017-182 (shared gen tie line)

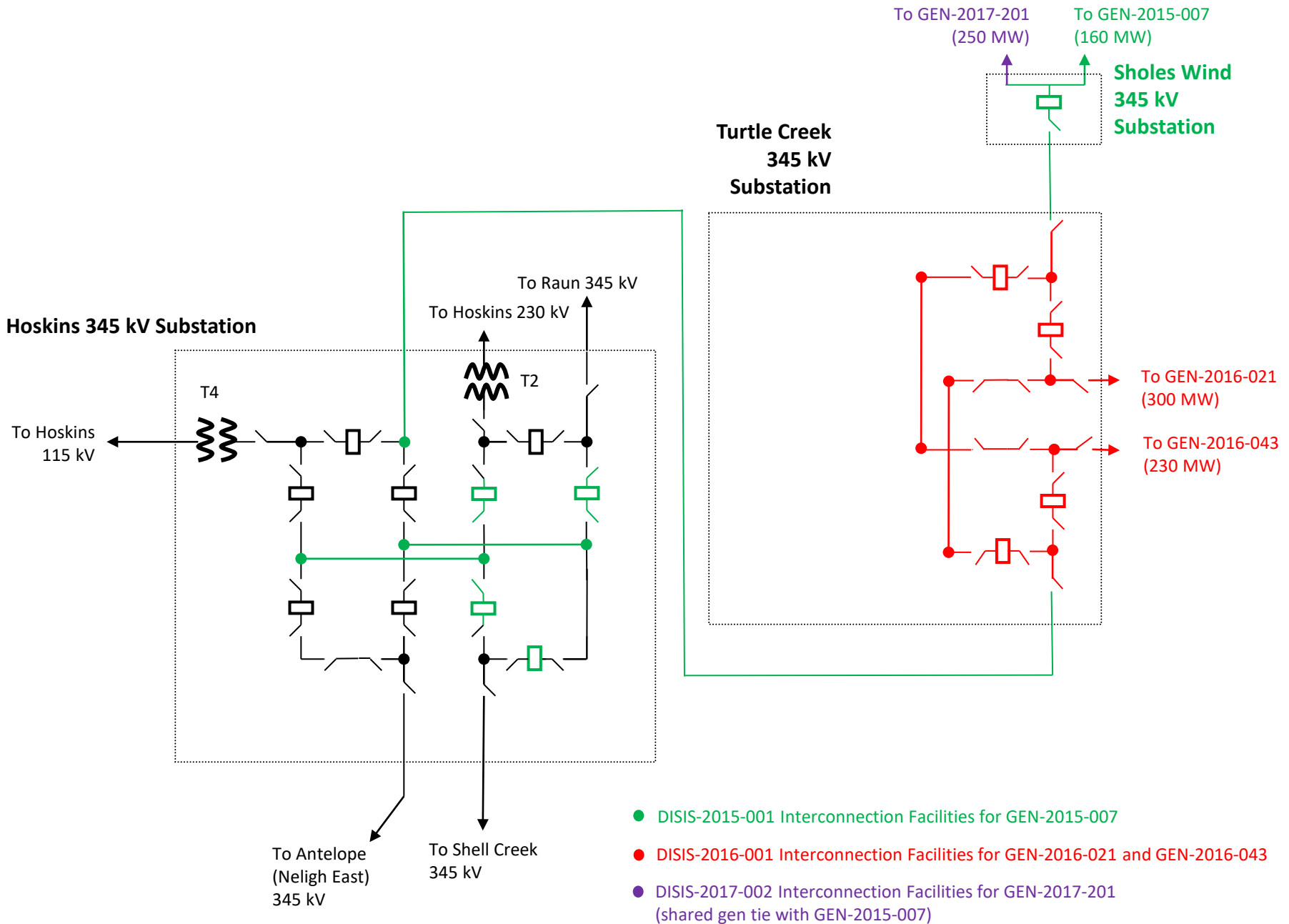

McCool 345 kV Substation

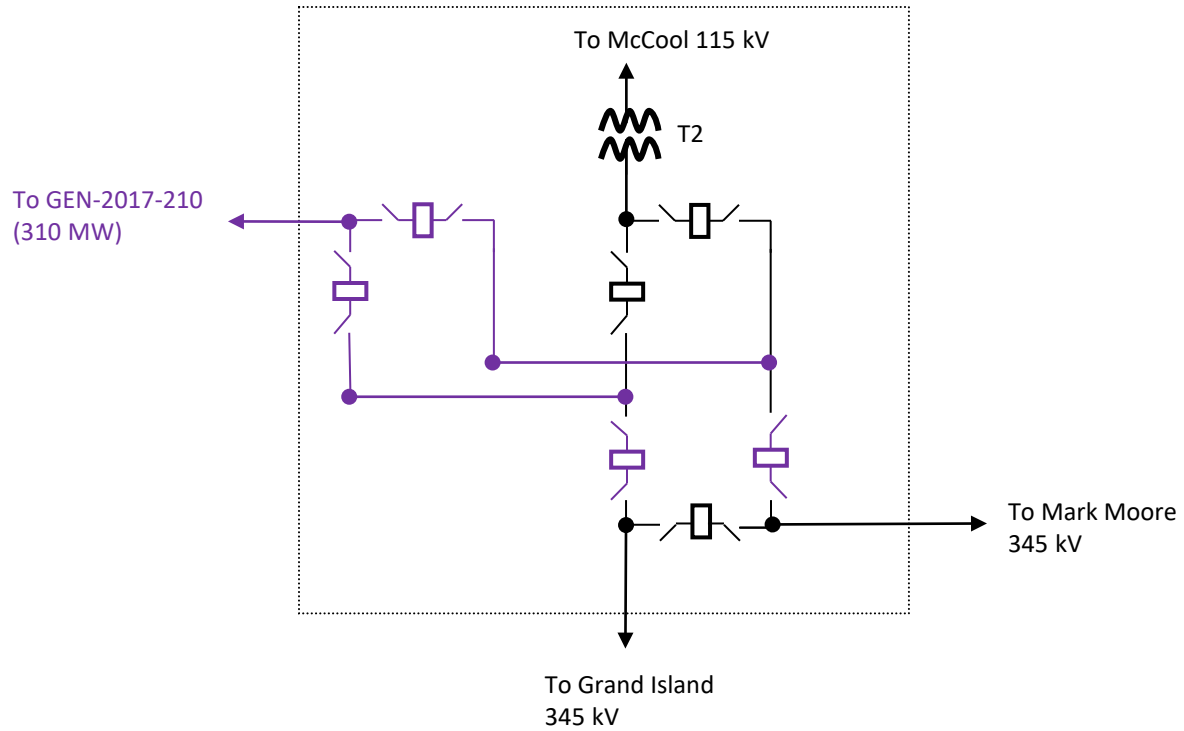

- DISIS-2017-002 Interconnection Facilities for GEN-2017-210

Greeley 115 kV

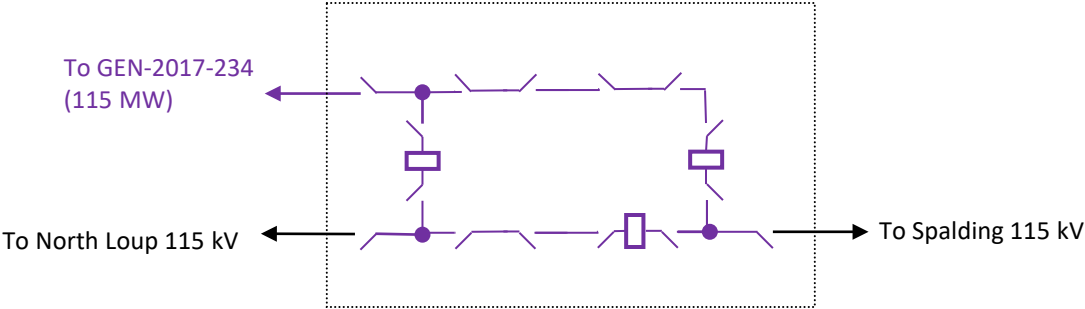

- DISIS-2017-002 Interconnection Facilities for GEN-2017-234